



扫描二维码
关注康力电梯门户网站
Scan the QR code and pay attention to
CANNY ELEVATOR Portal Website.



扫描二维码
关注康力电梯微信公众号
Scan the QR code and pay attention to
CANNY ELEVATOR WeChat Public Number

康力电梯股份有限公司
CANNY ELEVATOR CO.,LTD.

- ◎地址：江苏省汾湖高新技术产业开发区康力大道888号
- ◎电话：0512-63290000
- ◎传真：0512-63293938
- ◎网址：www.canny-elevator.com
- ◎电子信箱：(国内) marketing@canny-elevator.com
(国外) export-canny@163.com
export@canny-elevator.com
- ◎400客户服务热线：400-188-2367
- ◎邮编：215213

- ◎Add: No.888, Kangli Road, FOHO New & Hi-Tech Industrial
Development Zone, Jiangsu Province, China.
- ◎Tel: +86-512-63290000 63297851
- ◎Fax: +86-512-63299709
- ◎URL: www.canny-elevator.com
- ◎E-mail: export-canny@163.com
export@canny-elevator.com
- ◎P.C: 215213

本书为一般信息类出版物，我们保留随时更改产品设计和说明的权利，所有图片和颜色可能与实物有所不同，请以实物为准。
康力电梯股份有限公司©版权所有 2016-V1.0版



SILVER
SWALLOW

KLK1
银燕系列乘客电梯
KLK1 PASSENGER ELEVATOR

人性空间 · 至善至美

User-friendly Space, Pursuit of Perfection

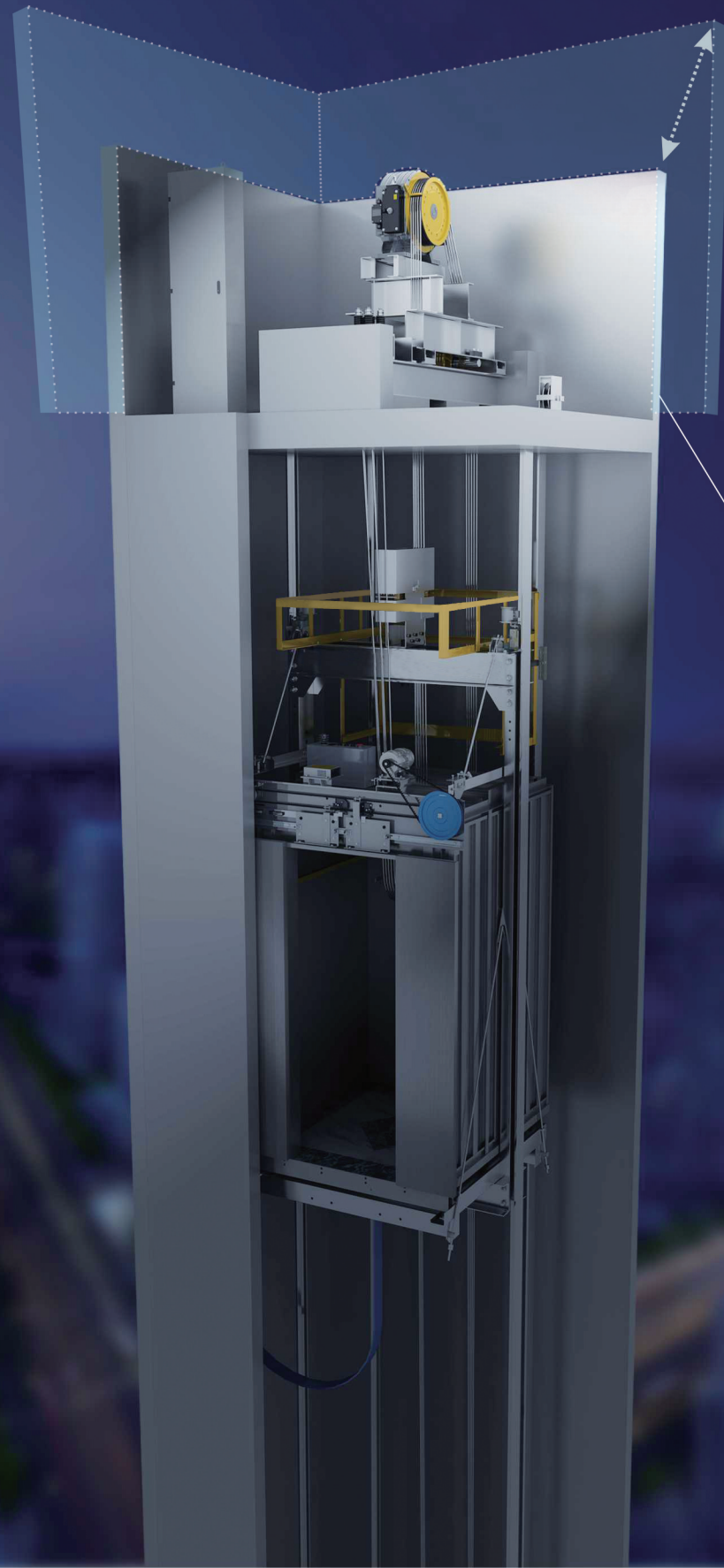

机房空间减少



Reduced by 25%

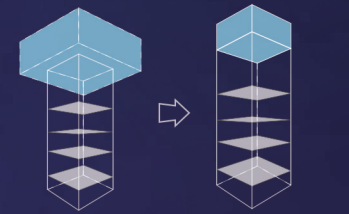

普通电梯的机房
Machine room in the ordinary lift

小机房电梯的机房
Machine room in small machine room lift

建筑设计更自由

节省空间

提高建筑利用率

维修更方便、安全

More Free Architectural Design
Saving Space
Improving the utilization of buildings
Making maintenance much easier and safe

新一代永磁同步无齿轮曳引机

- ◆ 高精度密封轴承，转矩更大，效率更高
- ◆ 同轴传动技术，节能达30%以上
- ◆ 无需更换润滑油，减少油污污染
- ◆ 消除了传统传动引起的噪音和振动，安静平稳



30%
节省能源



安静平稳

A new generation of permanent magnet synchronous gearless traction machine

High precision sealed bearing, with greater torque and higher efficiency.
Technology, which saves more than 30% of energies. Coaxial transmission
No need to replace the lubricant, which reduces oil contamination.
Eliminate the noise and vibration caused by traditional transmission, which helps realize quietness and smoothness.

节省空间

采用康力量身定制的紧凑型控制柜和永磁同步曳引机，有效节省井道空间，提高建筑空间利用率。

节能低耗

LED灯使用寿命长，耗电量少，灯光更柔和，电能只为白炽灯的五分之一。

自动唤醒

当固定时间内无人唤梯时，轿厢内照明及风扇将自动关闭，当有乘客召唤时，设备将自动启动，节省电梯非运行时间耗费的能源。

	LED灯 LED spotlight	80W普通荧光灯 80W ordinary fluorescent lamp
平均照度 Average intensity of illumination	80lx	About 80lx
寿命 Life	约3万小时 About 30000 hours	约6千小时 About 6000 hours
耗电量 Power consumption	约15W About 15W	约80W About 80W
废弃物 Discard	无 No	有 Yes

Space Saving

The adoption of the compact control cabinet and the permanent magnet synchronous traction machine customized for CANNY saves the space of the hoistway and improves the utilization of the construction space.

Energy Saving and Low Consumption

The LED light has the advantages of long service life, and low energy cost with softer lighting; besides, the electricity consumed is just one fifth of that consumed by incandescent light bulb.

Automatic waking device

When nobody calls for the elevator in a fixed time period, the light and the fan in the car will automatically shut off; When someone calls, the device will automatically start, saving energy during the standing time.

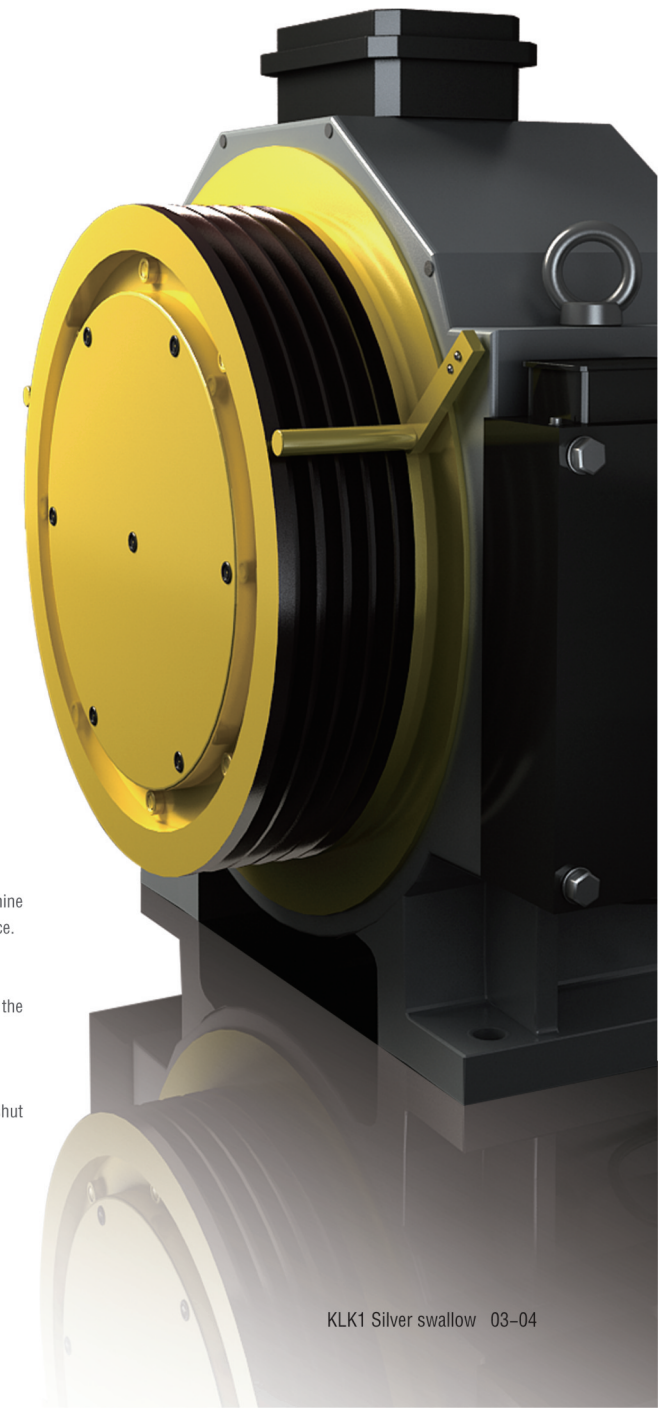



人性科技·创享安全

User-friendly technology · safe and reliable

◆ 抱闸力自检测及监视功能

主动定期测试抱闸力，通过提示故障及禁止电梯运行等方式，防止严重事故发生。

◆ 曳引绳滑动检测

实时监测滑动数据并且根据需要自动进入应急减速的安全运行模式。

◆ 光幕安全网

对于进入其探测区域的人或物做出灵敏反应，设计更体贴，保护更周到。

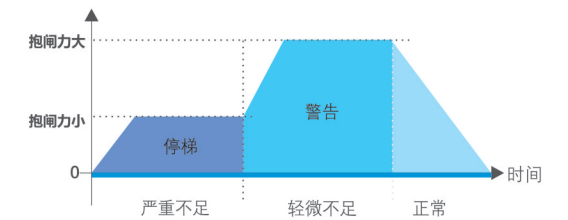

Braking Force Self-Detecting and Monitoring Function

It can test the braking force regularly, and prevent serious accidents from happening by prompting failure and stopping elevator from running.

Traction Rope Slide Detection

It provides real-time monitoring of sliding data, and can automatically enter the safe operation mode for emergency according to requirements.

Safety Light Curtain

It can make a sensitive response to people or objects in the detection area, the design is more thoughtful, and provides more thoughtful protection.



先进的红外光幕传感器
Advanced Infrared Light Curtain Sensor

领先升级·全新一代控制系统

New generation of control system, Leading upgrade

- ◆ 双32位高性能ARM芯片，可实现容错和监测功能，提高了系统的可靠性；
- ◆ 采用四层板表贴工艺，CAN总线串行通讯，保证了大量数据的高速、可靠传送；
- ◆ 超强的故障自诊与记录功能，确保电梯效率和安全；
- ◆ 采用分级密码进行参数设置，安全可靠，还可故障记录查询等操作，便于维修与调试。



ARM
32位高性能芯片



CAN
串行通讯

Double 32-bit high-performance ARM chip can achieve fault tolerance and monitoring function, improving the reliability of the system.
Four-layer board surface mount technology and CAN bus serial communication are adopted to ensure the high-speed, reliable transmission of mass data;
Super fault-diagnosis and fault recording function ensure the efficiency and safety of elevator;
Grading password is adopted for parameter setting, it is safe and reliable, and can inquire fault records, making maintenance and commissioning much easier.

人性关怀·平稳舒适

User-friendly · Smooth and Comfortable

◆ 变频门机系统

具备高效自学能力的门负载检测器，开关门速度可自由调节，使系统运行舒适平稳。

◆ 新一代VVVF变频器

可根据轿厢负载，调整电流大小和相位，精确控制主机转动转矩，确保电梯稳定运行。

Frequency conversion door system

Equipped with effective door load detector capable of self-learning, the speed of door opening and closing can be freely adjusted, making the whole system run comfortably and smoothly.

New generation of VVVF Inverter

Capable of the adjustment of current magnitude and phase and the precise control of driving torque of main engine, so as to ensure the stable running of elevator.



变频门机系统



安静平稳



尊崇之道·随心而选

Intelligent Technology, Choice of Heart

IC卡智能管理系统(可选)

轿厢内IC卡智能设置系统: 采用IC卡智能识别系统, 乘客进入轿厢内便可实现刷卡到户的快捷之旅。

IC card intelligent management (Optional)

The renewable energy into electrical energy back to the local power grid use, energy consumption is reduced by 30%.

- 1. 呼梯
- 2. 入口楼层读取
- 3. 进入轿厢
- 4. 轿内选择权限楼层

可选择任一平层, 无需按钮自动到达所住楼层。

- 1. Call
 - 2. Read card at entrance floor
 - 3. Select Floor No. in the elevator car
 - 4. Enter the elevator car
- Each floor can be selected for leveling, without pressing any button, it will automatically reach the designated floor of user.

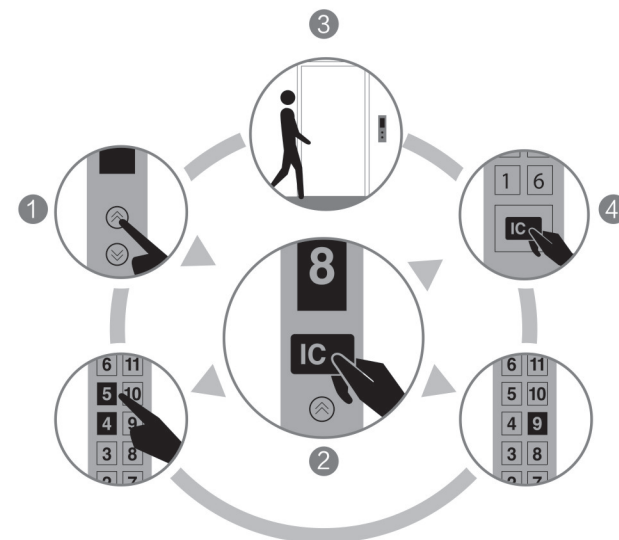

群控智能派梯系统(可选)

运用智能分散待梯原则, 以最快速度、最高效率运载乘客。

Group controlling intelligent dispatching system (Optional)

Abiding by the principle of intelligent dispersed principle, carry passengers with highest speed and efficiency.

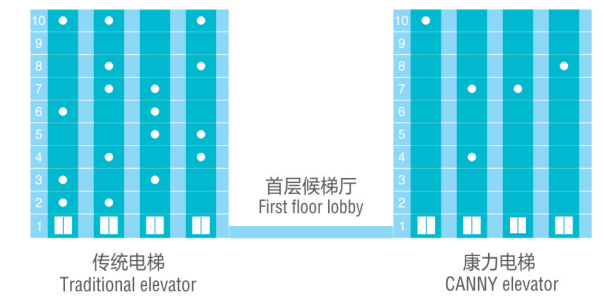

停电应急平层功能(可选)

电网停电后由电梯自动应急平层装置供电运行至最近层站平层开门。

Leveling for power failure (Optional)

After the outage by elevator automatic emergency power leveling device running to the nearest landing door leveling.

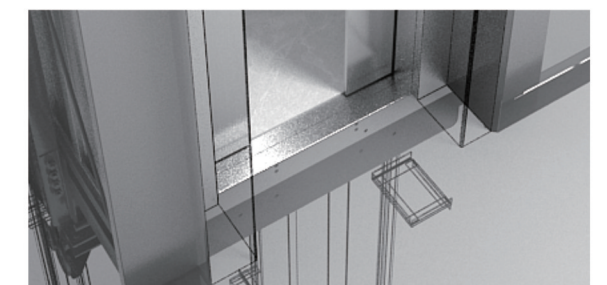

“赛能”能量回馈再生技术(可选)

将再生能源转化成电能回馈给局域网使用, 能耗降低30%。

CANEN energy re-generation feedback technology (optional)

The renewable energy into electrical energy back to the local power grid use, energy consumption is reduced by 30%.

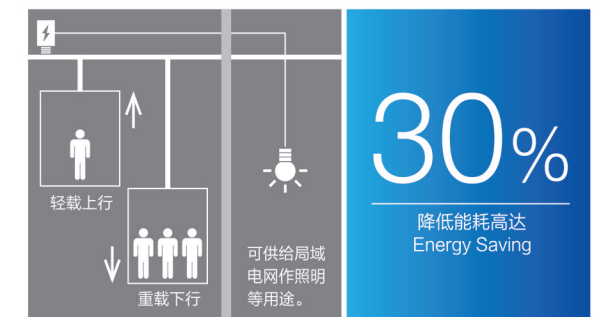

更多可选功能

More optional function



远程监控
Long-distance monitor



提前开门功能
Door opening in advance



BAS楼宇监控
Building Automation System



防捣乱功能
Anti-nuisance

标准型设计 Standard Design

王者风范 KL/K4-2001

标配 Standard configuration

- 轿壁：发纹不锈钢
- 前壁：发纹不锈钢
- 立柱：发纹不锈钢
- 操纵壁：KL231C一体式操纵箱，发纹不锈钢
- 轿门：发纹不锈钢
- 地板：KL/JD-4004 (PVC)
- 踢脚线：发纹不锈钢



Car wall: Hairline stainless steel Front wall: Hairline stainless steel
Vertical column: Hairline stainless steel Operation panel: KL231C, Hairline stainless steel
Car door: Hairline stainless steel Floor: KL/JD-4004 (PVC) Skirting: Hairline stainless steel



吊顶
Ceiling

KL/DD-4004
喷粉钢板，中撑小圆孔，LED光源
更环保，更节能
Dusting steel plate, Square grid in the middle, LED light source
Environmental protection, energy-saving



包边立柱
Trimmed Column

采用不锈钢包边，
整体更美观，更结实，更防撞
Stainless steel edging,
More beautiful, solid and crash-proof

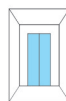

轿门
Car door

发纹不锈钢
Hairline stainless steel



扫描二维码360度了解轿厢
Scan the QR code to know more about the lift car
in the 360-degree manner

时尚节能

舒适温馨的同时享受不同的空间体验

Fashionable and Energy-saving
Comfortable and Providing different spatial experiences

Silver Swallow Passenger Elevator | 银燕乘客电梯·装潢设计

完美配置

与高品质面板完美组合，整个轿厢清新素雅，气质内敛。

Perfect configuration
It matches perfectly with high-quality panel, making the entire car fresh and elegant, with restrained temperament.

细节考究

整体式不锈钢包边，干净、整洁、易维护

Exquisite Details
The integrated stainless steel tipping, clean, tidy and easy for maintenance.

美观实用

具有较强的耐磨性质，防滑、防潮易保养

Beautiful and Practical
It has strong wear resistance properties, it is anti-skidding, moisture-proof and easy for maintenance

选配型设计 Optional Design

友谊长存 KL/K4-2002

(有偿选配 Charged optional)

吊顶: KL/DD-4005, 喷粉钢板, 亚克力, LED光源
轿壁: 钛金镜面蚀刻(中间), 贴塑钢板(两侧)
前壁: 钛金发纹不锈钢 立柱: 钛金发纹不锈钢
操纵箱: KL231C一体式操纵箱, 钛金发纹不锈钢
地坪: KL/JD-4005(PVC) 轿门: 钛金发纹不锈钢
踢脚线: 钛金发纹不锈钢

Ceiling: KL/DD-4005, Dusting steel plate, acrylic, LED light source
Car wall: Titanium gold mirror etched (Middle) Model steel placed (Both side)
Front wall: Titanium gold hairline stainless steel
Vertical column: Titanium gold hairline stainless steel
Operation panel: KL231C Titanium gold hairline stainless steel
Floor: KL/JD-4005 (PVC) Car door: Titanium gold hairline stainless steel
Skirting: Titanium gold hairline stainless steel

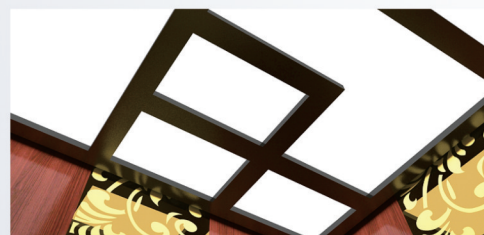
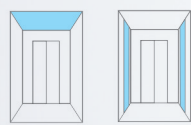

扫描二维码360度了解轿厢
Scan the QR code to know more about the lift car
in the 360-degree manner



选配型设计 Optional Design

林海雪原 KL/K4-2003

(有偿选配 Charged optional)

吊顶: KL/DD-4006, 喷粉钢板, 亚克力, LED光源
轿壁: 镜面蚀刻(中间) 贴塑钢板(两侧)
前壁: 镜面不锈钢 立柱: 镜面不锈钢
操纵箱: KL241C一体式操纵箱, 镜面不锈钢
轿门: 镜面不锈钢 地坪: KL/JD-4006(PVC)
踢脚线: 发纹不锈钢

Ceiling: KL/DD-4006, Dusting steel plate, acrylic, LED light source
Car wall: Mirror etched (Middle) Model steel placed (Both side)
Front wall: Mirror stainless steel
Vertical column: Mirror stainless steel
Operation panel: KL241C Mirror stainless steel
Car door: Mirror stainless steel
Floor: KL/JD-4006 (PVC)
Skirting: Hairline stainless steel

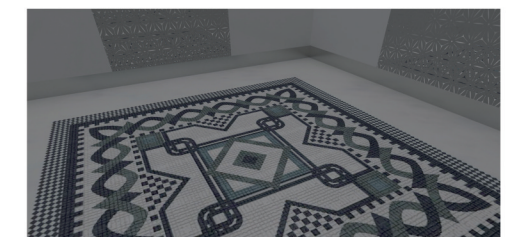
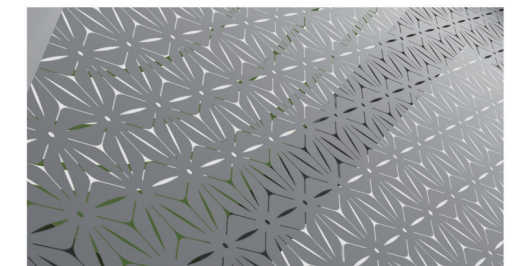
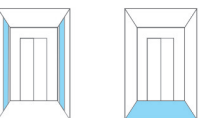

扫描二维码360度了解轿厢
Scan the QR code to know more about the lift car
in the 360-degree manner

深轿厢设计

Deep Car Decoration



KL/K4-2001S-1

(深轿厢标准配置 Standard configuration)

吊顶: KL/DD-4004, 喷粉钢板, 中撑小圆孔, LED光源
 轿壁/前壁: 发纹不锈钢 立柱: 发纹不锈钢
 操纵箱: KL231C一体式操纵箱(前壁), 发纹不锈钢
 轿门: 发纹不锈钢 地板: KL/JD-4004(PVC)
 踢脚线: 发纹不锈钢

Ceiling: KL/DD-4004, Dusting steel plate, hole on center support, LED light source
 Car wall: Hairline stainless steel
 Front wall: Hairline stainless steel
 Vertical column: Hairline stainless steel
 Operation panel: KL231C (front wall), Hairline stainless steel
 Car door: Hairline stainless steel
 Floor: KL/JD-4004 (PVC)
 Skirting: Hairline stainless steel



KL/K4-2001S-2

(深轿厢标准配置 Standard configuration)

吊顶: KL/DD-4004, 喷粉钢板, 中撑小圆孔, LED光源
 轿壁/前壁: 发纹不锈钢 立柱: 发纹不锈钢
 操纵壁: KL231C一体式操纵箱(侧壁),发纹不锈钢
 轿门: 发纹不锈钢 地板: KL/JD-4004(PVC)
 踢脚线: 发纹不锈钢

Ceiling: KL/DD-4004, Dusting steel plate, hole on center support, LED light source
 Car wall: Hairline stainless steel Front wall: Hairline stainless steel
 Vertical column: Hairline stainless steel
 Operation panel: KL231C (side wall)
 Car door: Hairline stainless steel
 Floor: KL/JD-4004 (PVC) Skirting: Hairline stainless steel

一体式操纵盘

Integrated operation panel

整体式美学设计, 与轿壁自成一派, 彰显雅致风范
 Integrated aesthetic design matches the car wall as one, highlighting the elegant demeanor

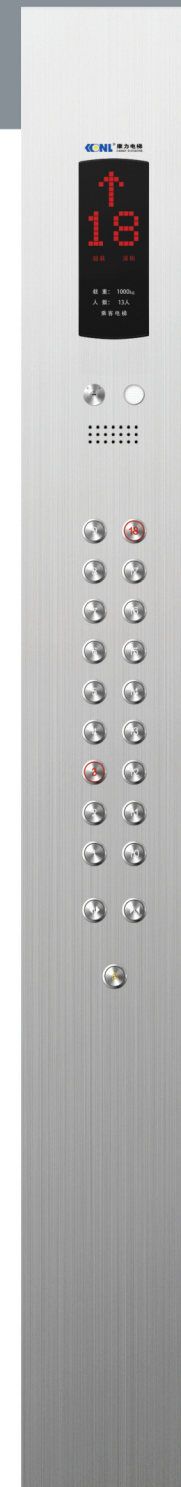

显示屏 Display screen
 点阵显示屏 Dot matrix display
 停层数 Parking number
 2-48停层 2-48 stop layer



面板材质: 发纹不锈钢
 Panel material: Hairline stainless steel

可选按钮
 Button optional



KL231C
 标配
 Standard



KL232C
 无偿选配
 Free optional



面板材质: 镜面不锈钢
 Panel material: Mirror stainless steel

可选按钮
 Button optional



KL241C
 有偿选配
 Charged optional



KL242C
 有偿选配
 Charged optional



显示屏 Display screen
 液晶显示屏 Liquid crystal display
 停层数 Parking number
 2-48停层 2-48 stop layer



面板材质: 发纹不锈钢
 Panel material: Hairline stainless steel

可选按钮
 Button optional



KL233C
 有偿选配
 Charged optional



KL234C
 有偿选配
 Charged optional



面板材质: 镜面不锈钢
 Panel material: Mirror stainless steel

可选按钮
 Button optional



KL243C
 有偿选配
 Charged optional



KL244C
 有偿选配
 Charged optional

嵌入式操纵盘 Embedded Control Panel

嵌入式操纵盘，满足多样化操纵功能定制，结构更坚固，维护更方便。

The imbedded operating panel meets the customization of the diversified control functions, thus making the structure more solid and the maintenance more convenient.

显示屏
多媒体显示屏
停层数
2-48停层

Display screen
LCD display
Parking number
2-48 stop layer

显示屏
点阵显示屏
停层数
2-48停层

Display screen
Dot matrix display screen
Parking number
2-48 stop layer

显示屏
轿内横显
停层数
2-48停层

Display screen
Car indicator
Parking number
2-48 stop layer

一体式操纵盘 (有偿选配) Integrated operation panel (charged optional)

面板材质: 发纹不锈钢
Panel material: Hairline stainless steel

可选按钮
Button optional

可选屏幕尺寸
Optional screen size

		
		
KL235C 有偿选配 Charged optional	KL237C 有偿选配 Charged optional	KL239C 有偿选配 Charged optional
		
KL236C 有偿选配 Charged optional	KL238C 有偿选配 Charged optional	KL23AC 有偿选配 Charged optional

面板材质: 镜面不锈钢
Panel material: Mirror stainless steel

可选按钮
Button optional

可选屏幕尺寸
Optional screen size

		
		
KL245C 有偿选配 Charged optional	KL247C 有偿选配 Charged optional	KL249C 有偿选配 Charged optional
		
KL246C 有偿选配 Charged optional	KL248C 有偿选配 Charged optional	KL24AC 有偿选配 Charged optional

面板材质: 发纹不锈钢
Panel material: Hairline stainless steel

可选按钮
Button optional

	
KL261C 标配 Standard	KL262C 无偿选配 Free optional

面板材质: 镜面不锈钢
Panel material: Mirror stainless steel

可选按钮
Button optional

	
KL271C 有偿选配 Charged optional	KL272C 有偿选配 Charged optional

轿内横显
Car indicator

可选按钮
Button optional

	
KL265C 无偿选配 Free optional	KL266C 无偿选配 Free optional



面板材质: 镜面不锈钢
Panel material: Mirror stainless steel

KL275C
有偿选配
Charged optional

KL276C
有偿选配
Charged optional

轿内横显
Car indicator

可选按钮
Button optional

	
KL267C 有偿选配 Charged optional	KL268C 有偿选配 Charged optional

面板材质: 镜面不锈钢
Panel material: Mirror stainless steel

KL277C
有偿选配
Charged optional

KL278C
有偿选配
Charged optional

人机界面 Man-machine interface

感受人性化乘梯体验，多种材质选择，多项功能设置，完美互动一触即发
User friendly transportation experience, optional materials, multiple functions, perfect interaction

无底盒召唤指示器(单梯)

Calling Indicator Without Bottom Box (single elevator)



安装方式对比 Contrast installation

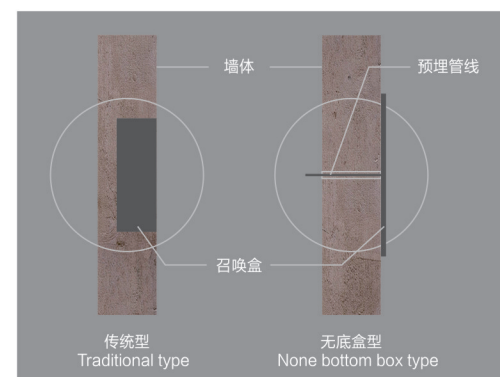

传统型：土建时需预先留孔，耗时耗力。
无底盒型：只需预埋管线，无需土建留孔，安装维修更便捷。
Conventional: When leaving holes to be pre-civil, time-consuming and labor-intensive. Bottomless box type: simply embedded pipeline, without leaving holes civil engineering, installation and maintenance more convenient.

无底盒召唤指示器(双梯)

Calling Indicator Without Bottom Box(Double Elevator)



无底盒消防盒与锁梯盒

Fire Protection Box And Elevator locking box Without Bottom Case

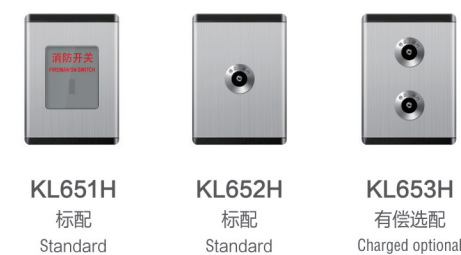

可选面板材质 Panel material optional



残疾人操纵盘 Operation panel for disabled

可选面板材质：发纹不锈钢/镜面不锈钢
Panel material: Hairline/Mirror stainless steel



层站横式指示器(无到站灯) 有偿选配

Horizontal indicator for landing(without arrival lamp) Charged optional

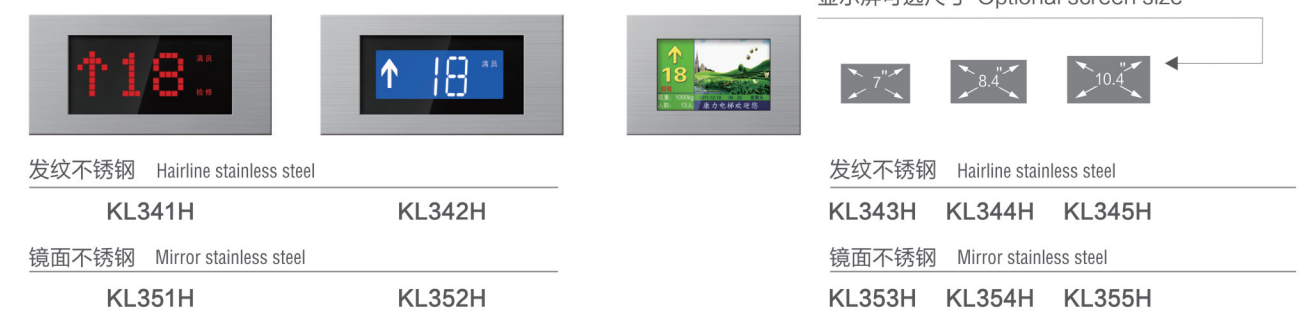

层站横式指示器(带到站灯) 有偿选配

Horizontal indicator for landing(with arrival lamp) Charged optional



人机界面 Man-machine interface



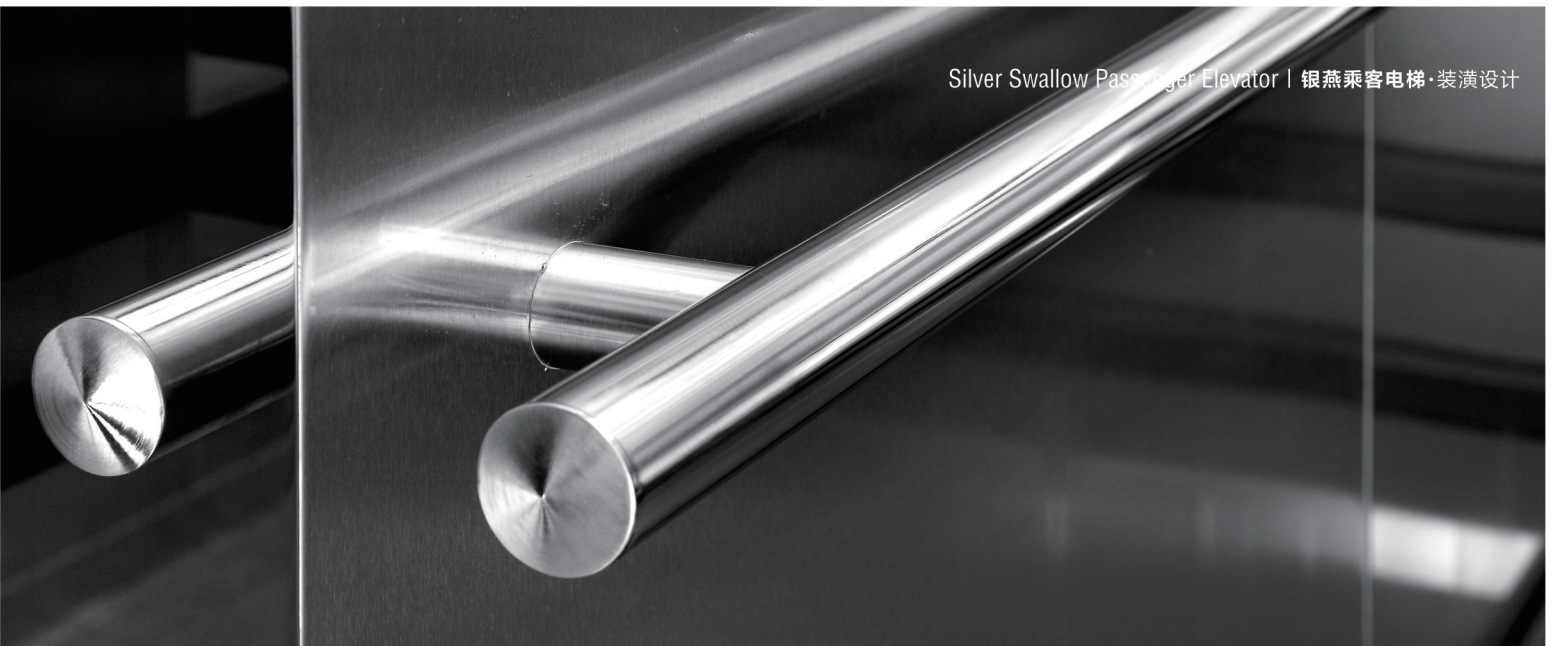



感受人性化乘梯体验，多种材质选择，多项功能设置，完美互动一触即发
User friendly transportation experience, optional materials, multiple functions, perfect interaction











嵌入式层站召唤盒(带层显) Embedded Calling box for landing (with floor display)

 <p>KL301H 无偿选配 Free optional 点阵显示 Dot matrix display</p>	 <p>KL303H 有偿选配 Charged optional 液晶显示 Liquid crystal display</p>	 <p>KL305H 有偿选配 Charged optional 点阵显示 Dot matrix display</p>	 <p>KL307H 有偿选配 Charged optional 液晶显示 Liquid crystal display</p>
 <p>KL302H 无偿选配 Free optional 点阵显示 Dot matrix display</p>	 <p>KL304H 有偿选配 Charged optional 液晶显示 Liquid crystal display</p>	 <p>KL306H 有偿选配 Charged optional 点阵显示 Dot matrix display</p>	 <p>KL308H 有偿选配 Charged optional 液晶显示 Liquid crystal display</p>

层站召唤按钮(无层显) Calling button for landing (without floor display)

 <p>KL321H 有偿选配 Charged optional</p>	 <p>KL323H 有偿选配 Charged optional</p>	 <p>KL325H 有偿选配 Charged optional</p>	 <p>KL327H 有偿选配 Charged optional</p>
 <p>KL322H 有偿选配 Charged optional</p>	 <p>KL324H 有偿选配 Charged optional</p>	 <p>KL326H 有偿选配 Charged optional</p>	 <p>KL328H 有偿选配 Charged optional</p>







层站到站灯(有偿选配) Arrival lamps for landing (Charged optional)

 <p>KL361H (发纹不锈钢) Hairline stainless steel</p>	 <p>KL362H (发纹不锈钢) Hairline stainless steel</p>	 <p>KL363H (发纹不锈钢) Hairline stainless steel</p>	 <p>KL364H (发纹不锈钢) Hairline stainless steel</p>
 <p>KL371H (镜面不锈钢) Mirror stainless steel</p>	 <p>KL372H (镜面不锈钢) Mirror stainless steel</p>	 <p>KL373H (镜面不锈钢) Mirror stainless steel</p>	 <p>KL374H (镜面不锈钢) Mirror stainless steel</p>

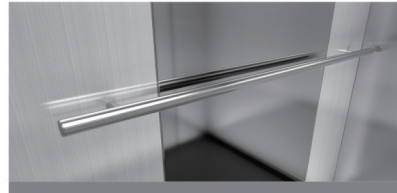
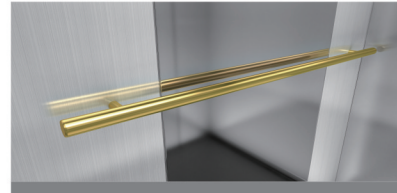
可选面板材质 Panel material optional

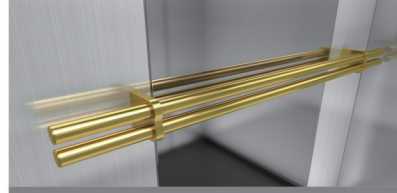
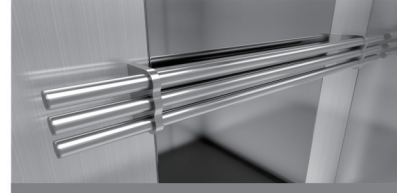
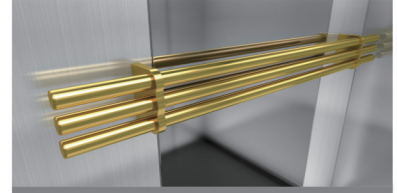
 <p>发纹不锈钢 Hairline stainless steel</p>	 <p>镜面不锈钢 Mirror stainless steel</p>
---	--

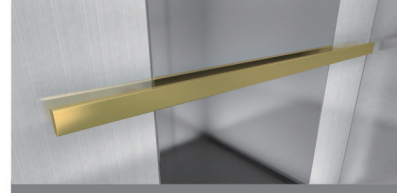
扶手(可选) Handrail (optional)

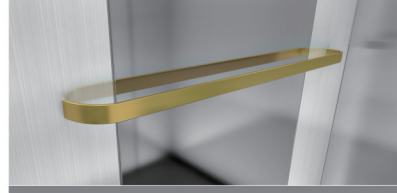
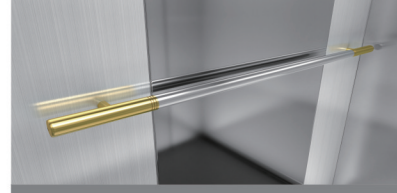
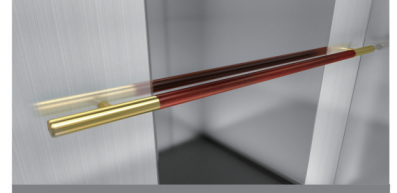
 <p>KL-FS 001</p> <p>发纹不锈钢单管 Stainless steel hairline mono-tube</p>	 <p>KL-FS 002</p> <p>镜面钛金不锈钢单管 Titanium gold mirror stainless steel mono-tube</p>	 <p>KL-FS 003</p> <p>发纹不锈钢双管 Stainless steel hairline double-tube</p>
 <p>KL-FS 004</p> <p>镜面钛金不锈钢双管 Titanium gold mirror stainless steel double-tube</p>	 <p>KL-FS 005</p> <p>发纹不锈钢三联管 Stainless steel hairline tri-tube</p>	 <p>KL-FS 006</p> <p>镜面钛金不锈钢三联管 Titanium gold mirror stainless steel tri-tube</p>
 <p>KL-FS 007</p> <p>发纹板方扶手 Hairline plate, square handrail</p>	 <p>KL-FS 008</p> <p>钛金板方扶手 Titanium gold plate, square handrail</p>	 <p>KL-FS 009</p> <p>不锈钢短纹，圆弧头 Short grain stainless steel, arc head</p>
 <p>KL-FS 010</p> <p>钛金不锈钢短纹，圆弧头 Short grain titanium gold stainless steel, arc head</p>	 <p>KL-FS 011</p> <p>不锈钢，钛金组合 Combination of stainless steel and titanium gold</p>	 <p>KL-FS 012</p> <p>圆木和钛金组合 Combination of round wood and titanium gold</p>



吊顶 Ceiling

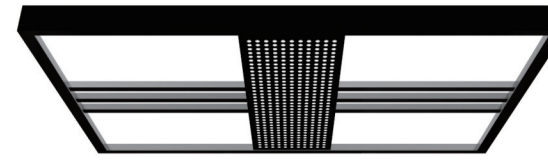

KL/DD-4004 标配 Standard
喷粉钢板, 中撑小圆孔, LED光源
Dusting steel plate, hole on center support, LED light source



KL/DD-4005 无偿选配 Free optional
喷粉钢板, 亚克力, LED光源
Dusting steel plate, acrylic, LED light source



KL/DD-4006 无偿选配 Free optional
喷粉钢板, 亚克力, LED光源
Dusting steel plate, acrylic, LED light source



KL-D 001 无偿选配 Free optional
双拱形白色有机透光板, 中部LED灯的柔光照明设计
Double arched white organin light emitting board plus the gentle light illumination of the mid down light

喷粉色标(可选) Dusting color standard (optional)

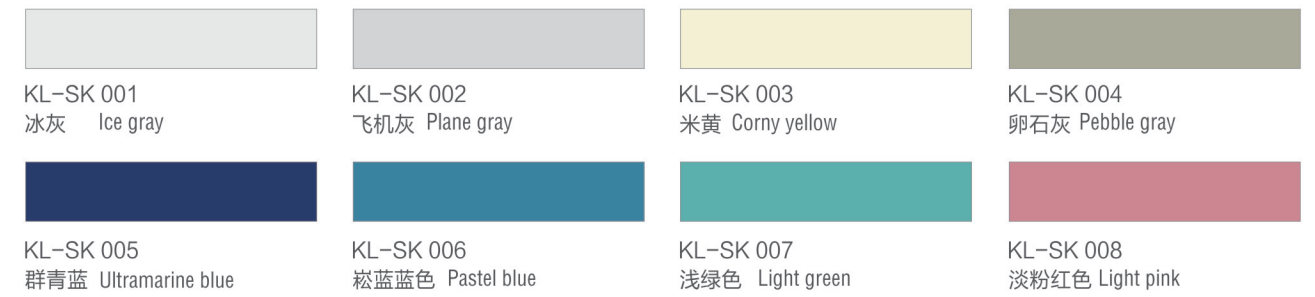

厅门 Landing Door



KL-TM 001 标配 Standard 厅门: 发纹不锈钢 Landing Door: Hairline stainless steel 门套: 发纹不锈钢 Jamb: Hairline stainless steel	KL-TM 002 标配 Standard 厅门: 喷粉钢板 Landing Door: Dusting steel plate 门套: 喷粉钢板 Jamb: Dusting steel plate	KL/M-4013 可选 Optional 厅门: 蚀刻不锈钢 Landing Door: Etched stainless steel 门套: 发纹不锈钢 Jamb: Hairline stainless steel	KL/M-4033 可选 Optional 厅门: 镜面, 浮雕, 钛黑 Landing Door: Mirror, Relief, Titanium black stainless steel 门套: 镜面不锈钢 Jamb: Mirror stainless steel
---	---	---	--

蚀刻花纹(可选) Etching pattern (optional)



PVC地板(可选) PVC Floor (optional)



先进功能设计 Advanced functional design

● 标准; ○ 无偿选配; ○ 有偿选配
● Standard ○ Free optional ○ Charged optional

● 抱闸力检测 Braking Force Self-Detecting	主动定期测试抱闸力，通过提示故障及禁止电梯运行等方式，防止严重事故发生。 Actively and regularly test the brake force; prevent more serious accident by means of malfunction indication and running prohibition and so on.
● 曳引绳滑动检测 Traction Rope Slide Detection	实时监测滑动数据并且根据需要自动进入应急减速的安全运行模式。 It provides real-time monitoring of sliding data, and can automatically enter the safe operation mode for emergency according to requirements.
● 抱闸检测保护 Brake detection protection	通过抱闸臂检测开关对抱闸的打开与闭合实时监测。当抱闸未按要求打开时，系统将禁止电梯启动。 Brake arm detection switch executes real-time monitor to brake opening / closing. If the brake does not open by the requirements, the system will not start the elevator.
● 门区外不能开门的保护 Protection of none door opening outside door zone	在非门区状态，禁止自动开门。 Automatic door opening is forbidden under none door zone condition.
● 低速保护 Low-speed protection	为防止电梯在控制范围外低速运行导致安全问题而设置的保护。 It prevents elevator from low-speed running outside the control range causing any safety problem(s).
● 超载保护 Overload protection	在电梯关门运行前，当检测到超载信号时，电梯不能关门运行，并且关门按钮无效。超载消除后自动恢复正常。 Before the elevator shuts the door, if it detects overload signal, the elevator does not shut then, "door-shut button" becomes effective. After it removes overload problem, it re-starts automatically.
● 故障自动靠站 Automatic parking in trouble	正常运行中的电梯因故障在非平层区域内停止时，只要不是安全装置动作而引起，则电梯以低速向中间楼层方向进行自救运行，并在最近服务层停层开门，以防止困人事故的发生。 When the elevator stops in none leveling zone due to any trouble, if it is not caused by safety device action, it executes self-rescue running towards the middle floor direction at low speed. It parks and opens the door at the nearest service floor to prevent from any trapping accident.
● 电梯受阻保护 Protection of elevator blockage	系统发出启动命令，但在预定的时间内未能正常启动，或电梯在运行，但在预定的时间内未能到达一定的距离，电梯停止运行。 When the system runs start command, it does not start within preset time nor because it is during the elevator travelling, and it does not reach certain distance within preset time as well, the elevator stops accordingly.
● 有司机运行 Attendant running	电梯工作在司机状态，系统按轿内指令信号运行。如有层站召唤信号，顺向层站召唤自动截车。平层停车后自动开门，但不自动关门，需由司机按动关门按钮。 When it is under the operator condition, the elevator system operates according to the car command signal. If landing call signal is available, it automatically cuts as per forward landing call. The door opens automatically after the leveling parking. But it does not shut automatically until the operator presses "door closing button".
● 消防返回 Fire-fighting return	消防开关关闭后系统进入消防返回状态：系统将消除所有层站召唤和轿内指令信号，自动返回消防基站，保持开门。如电梯正在反方向运行，则就近层停车不开门返回消防基站，保持开门。 When the fire-fighting switch closes, the system enters into fire-fighting running. The system will remove all the landing calls and car command signals, and it automatically returns to fire-fighting home landing, and the door keeps open. If the elevator is travelling in reverse direction, it parks at nearby floor, and returns to fire-fighting home landing with the door keeping closed, after that it keeps the door open.
○ 消防运行 Fire-fighting running	消防开关关闭后系统进入消防运行：系统将消除所有层站召唤和轿内指令信号，自动返回消防基站，保持开门。如电梯正在反方向运行，则就近层停车不开门返回消防基站，保持开门并由消防员控制运行。 When the fire-fighting switch closes, the system enters into fire-fighting running. The system will remove all the landing calls and car command signals, and it automatically returns to fire-fighting home landing, and the door keeps open. If the elevator is travelling in reverse direction, it parks at nearby floor, and returns to fire-fighting home
● 基站锁梯 Home landing elevator locking	电梯处于自动状态，关闭基站锁梯开关后，电梯将所登记的轿内指令服务完毕后自动返回基站，电梯进入驻停状态。一旦打开锁梯开关，电梯会立即退出驻停状态，投入正常运行。 When the elevator is under automatic condition, when it shuts home landing locking switch, the elevator will complete all the registered car command services, automatically return to home landing, it enters into parking condition. As soon as locking switch is on, it immediately returns from parking condition and goes into normal running.

● 标准; ○ 无偿选配; ○ 有偿选配
● Standard ○ Free optional ○ Charged optional

● 误登记取消 Cancel the error-register	若乘客误按了某层轿内指令按钮并已登记（轿内指令灯亮），则在电梯未运行状态下，只需再按一次该层轿内指令按钮即将该登记取消（轿内指令灯灭）。 If the passenger presses the car command button at certain floor and has registered it by mistake, (by then the car indicating lamp is bright), if under the condition of none elevator running, you only press the car command button at the same floor to cancel the register. (By then the car indicating lamp dies out.)
○ 轿厢到站钟 Car arrival gong	通过轿厢顶的钟声，提醒在轿厢内的乘客和等候在电梯候梯厅内的乘客该电梯即将到站。 Arrival gong on top of the car reminds the passengers in the car and those waiting in the hall that the elevator has arrived.
○ 语音报站 Phonic station reporter	由语音报站装置通知乘客电梯运行相关信息：在电梯到站前播报将要到站的层楼，在关门运行前播报将要运行的方向等。 Phonic station reporter informs the passengers of the relevant elevator running information. It announces the arriving landing, the traveling direction etc. before door-close and running.
● 通电自动开门 Electrified automatic door-opening	每次电梯上电，如轿厢正在门区，电梯门将自动打开。 Every time when the elevator is electrified, if the car is in the door zone, the elevator door opens automatically.
○ 自动返基站 Automatic return to home landing	无司机运行时，如果自动返基站功能设置有效，当无层站召唤信号时间到达预定的时间后，电梯自动返回基站。 In non-attendant running, if automatic return function to home landing is still effective, and no-landing call signal time fulfills preset time, the elevator returns to home landing automatically.
● 轿厢内照明及风扇自动停止 Automatic stop of the car illumination and fan	如一定时间电梯无人使用，轿厢内照明和风扇将自动关闭。接到任何层站召唤命令后自动打开。 If nobody uses the elevator within certain period of time, the car illumination and fan shut off automatically and re-opens on receiving any landing call command(s).
● 楼层信号自动校正 Automatic correction of floor signal	如果楼层显示位置有误差，系统在运行中检测到端站开关后，将自动校正楼层显示。 If the floor display position has error, after the system detects terminal switch in the travel, it will automatically correct the floor display.
● 轿内反向指令消除 Cancellation of the reverse command(s) in the car	当电梯运行至最远端楼层换速时，清除所有的轿内指令登记。 When the elevator travels to the farthest floor and changes the speed, it removes all the car command register.
● 呼梯按钮嵌入自诊断 Self-diagnostic embedded call button	若某一层站召唤按钮按下时间超过20秒而未断开，则系统认为该按钮嵌入。以后对该层层站召唤不予登记，且该按钮对应的应答灯不断闪烁报警。当该按钮断开时，退出上述状态。 If you press call button at certain landing for over 20 second, and it still does not disconnect, the system assumes that it is embedded button. It does not register the landing call of the same floor afterwards. Responsive lamp which corresponds to the button keeps flickering and alarming. When the button disconnects, it exits from above condition.
○ 再平层功能 Re-leveling function	电梯停在当前层，当过多乘客进入电梯或离开电梯时，由于钢丝绳的伸长或缩短，轿厢脱离平层区域，电梯将在开门的情况下以低速运行至平层位置。 If the elevator parks on the current floor, when too many passengers enter into / leave the elevator, the car is separated from the leveling zone because of wire rope extension or shortening. The elevator will then travel to the leveling position at low speed under the condition of door-opening.
○ 信号接口装置 Signal interface position	通过信号接口装置输出电梯的基本运行状态信号。 It outputs basic running condition signal through the signal interface device.
○ 自动应急平层运行 Automatic emergency leveling travel	如果自动应急平层功能设置有效，并配置了“自动应急平层装置”，满足自动应急平层条件，电网停电后由电梯自动应急平层装置供电运行到达最近层站的平层位置，开门，让乘客安全撤离轿厢。 If automatic emergency leveling function setting is effective, it is equipped with "automatic emergency leveling device" to satisfy automatic emergency leveling conditions. After power grid fails, automatic emergency leveling device supplies electricity and the elevator travels to the leveling position of the nearest landing. It opens the door, for safe evacuation of the passengers from the car.
○ 远程监控 Remote Monitoring	通过信号接口装置、及无线网络技术，用户只需登入相应服务器即可查看信息，对电梯故障率、故障时间等进行统计分析也可实现故障短信报警。 Through signal interface device and wireless network technology, user can log in the corresponding server to check information, make statistical analysis of elevator failure rate and failure time, and achieve fault message alarm.
○ 能量回馈 Energy feedback	当配置了能量回馈装置时，将电梯轻载上行和重载下行时产生的能量回馈电网或供周边设备使用，以达到节能目的。 When energy feedback device is installed, the energy produced during the elevator light-load up-motion and heavy-load down-motion will be used by power grid and the surrounding equipments. It fulfills the energy-saving purposes.

土建参数

Construction parameters

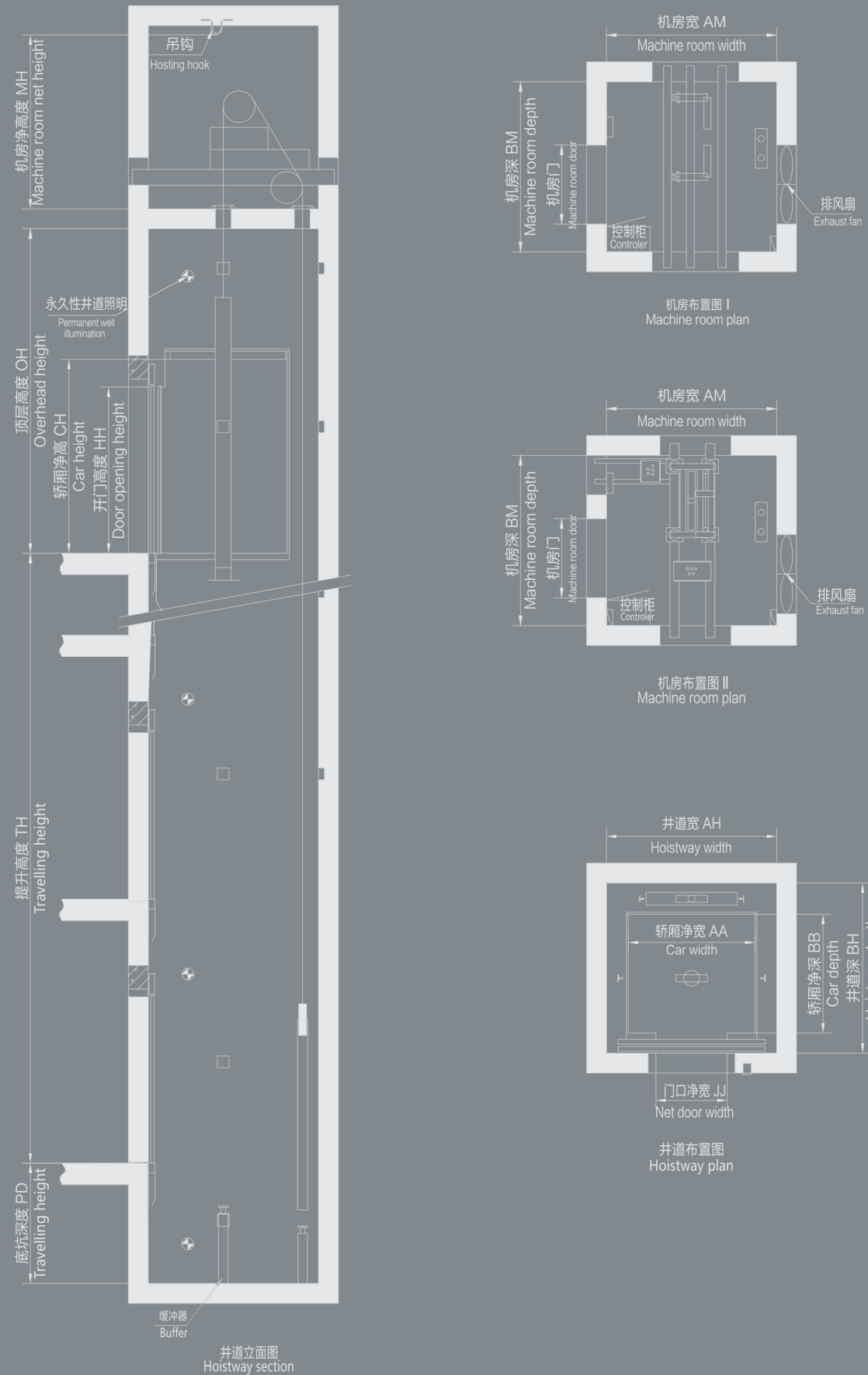

对重后置乘客电梯KLK1参数表（银燕系列）
Counterweight Rear Type Passenger Elevator KLK1(Silver Swallow Series)

载重量 (Kg) Loading capacity	额定速度 (m/s) Rated speed	开门宽度 (mm) Door opening width	开门高度 (mm) Door opening height	轿厢尺寸(mm) Car size			井道尺寸(mm) Hoistway size		机房尺寸(mm) Machine room size		顶层高度 (mm) Top floor height	底坑深度 (mm) Pit depth	最大提升高度 (m) Max.travelling height
				宽 Width	深 Depth	高 Height	宽 Width	深 Depth	宽 Width	深 Depth			
450	1.0	800	2100	1100	1100	2300	1900	1750	1900	1750	4150	1400	50
	1.6	800	2100	1100	1100	2300	1900	1750	1900	1750	4200	1400	60
630	1.0	800	2100	1400	1100	2400	1950	1750	1950	1750	4150	1400	50
	1.6	800	2100	1400	1100	2400	1950	1750	1950	1750	4200	1400	80
	1.75	800	2100	1400	1100	2400	1950	1750	1950	1750	4250	1450	90
800	1.0	800	2100	1400	1350	2400	1950	2000	1950	2000	4150	1400	50
	1.6	800	2100	1400	1350	2400	1950	2000	1950	2000	4200	1400	80
	1.75	800	2100	1400	1350	2400	1950	2000	1950	2000	4250	1450	90
	2.0	800	2100	1400	1350	2400	1950	2000	1950	2000	4550	1450	105/120
	2.5	800	2100	1400	1350	2400	1950	2000	1950	2000	4650	1600	80/105/120
1000	1.0	900	2100	1600	1400	2400	2150	2050	2150	2050	4150	1400	50
	1.6	900	2100	1600	1400	2400	2150	2050	2150	2050	4200	1400	80
	1.75	900	2100	1600	1400	2400	2150	2050	2150	2050	4250	1450	90
	2.0	900	2100	1600	1400	2400	2150	2050	2150	2050	4550	1450	105/120
	2.5	900	2100	1600	1400	2400	2150	2050	2150	2050	4650	1600	80/105/120
1050	1.0	900	2100	1600	1500	2400	2150	2150	2150	2150	4150	1400	50
	1.6	900	2100	1600	1500	2400	2150	2150	2150	2150	4200	1400	80
	1.75	900	2100	1600	1500	2400	2150	2150	2150	2150	4250	1450	90
	2.0	900	2100	1600	1500	2400	2150	2150	2150	2150	4550	1450	105/120
	2.5	900	2100	1600	1500	2400	2150	2150	2150	2150	4650	1600	80/105/120
1150	1.0	1100	2100	1800	1400	2400	2400	2050	2400	2050	4600	1600	50
	1.6	1100	2100	1800	1400	2400	2400	2050	2400	2050	4650	1650	80
	1.75	1100	2100	1800	1400	2400	2400	2050	2400	2050	4700	1700	90/105/120
	2.0	1100	2100	1800	1400	2400	2400	2050	2400	2050	4800	1750	80/105/120
	2.5	1100	2100	1800	1400	2400	2400	2050	2400	2050	5100	1950	120
1250	1.0	1100	2100	1950	1400	2400	2550	2050	2550	2050	4600	1600	50
	1.6	1100	2100	1950	1400	2400	2550	2050	2550	2050	4650	1650	80
	1.75	1100	2100	1950	1400	2400	2550	2050	2550	2050	4700	1700	90/120
	2.0	1100	2100	1950	1400	2400	2550	2050	2550	2050	4800	1750	80/120
	2.5	1100	2100	1950	1400	2400	2550	2050	2550	2050	5100	1950	120
1350	1.0	1100	2100	1950	1500	2400	2550	2150	2550	2150	4600	1600	50
	1.6	1100	2100	1950	1500	2400	2550	2150	2550	2150	4650	1650	80
	1.75	1100	2100	1950	1500	2400	2550	2150	2550	2150	4700	1700	90/120
	2.0	1100	2100	1950	1500	2400	2550	2150	2550	2150	4800	1750	80/120
	2.5	1100	2100	1950	1500	2400	2550	2150	2550	2150	5100	1950	120
1600	1.0	1100	2100	1950	1500	2400	2550	2150	2550	2150	5100	2200	150
	1.0	1100	2100	1950	1750	2400	2550	2400	2550	2400	4600	1600	50
	1.6	1100	2100	1950	1750	2400	2550	2400	2550	2400	4650	1650	80
1600	1.75	1100	2100	1950	1750	2400	2550	2400	2550	2400	4700	1700	90/120
	2.0	1100	2100	1950	1750	2400	2550	2400	2550	2400	4800	1750	80/120

土建参数

Construction parameters

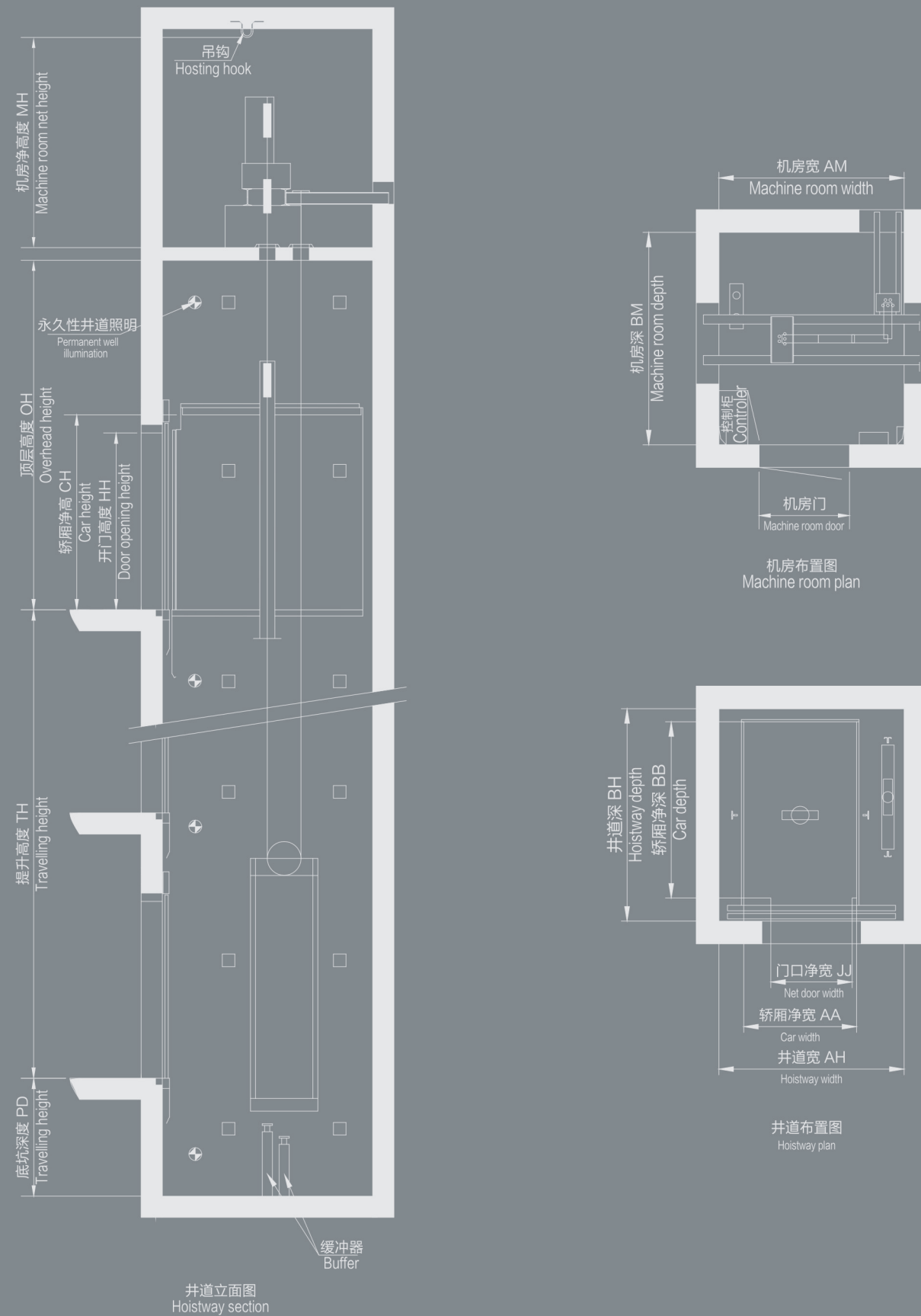

对重侧置乘客电梯KLK1参数表 (银燕系列)
Counterweight Side Type Passenger Elevator KLK1(Silver Swallow Series)

载重量 (Kg)	额定速度 (m/s)	开门宽度 (mm)	开门高度 (mm)	轿厢尺寸(mm)			井道尺寸(mm)		机房尺寸(mm)		顶层高度 (mm)	底坑深度 (mm)	最大提升高度 (m)
				宽	深	高	宽	深	宽	深			
630	1.0	800	2100	1100	1400	2400	1950/1900	1850/1900	1950/1900	1850/1900	4150	1400	50
	1.6	800	2100	1100	1400	2400	1950/1900	1850/1900	1950/1900	1850/1900	4200	1400	60
	1.75	800	2100	1100	1400	2400	1950/1900	1850/1900	1950/1900	1850/1900	4250	1450	90/95
800	1.0	800	2100	1100	1700	2400	1950/1900	2100/2150	1950/1900	2100/2150	4150	1400	50
	1.6	800	2100	1100	1700	2400	1950/1900	2100/2150	1950/1900	2100/2150	4200	1400	80
	1.75	800	2100	1100	1700	2400	1950/1900	2100/2150	1950/1900	2100/2150	4250	1450	90/105/120
	2.0	800	2100	1100	1700	2400	1950/1900	2100/2150	1950/1900	2100/2150	4350	1600	80/105/120
	2.5	800	2100	1100	1700	2400	2000/1950	2100/2150	2000/1950	2100/2150	5000	1950	105/120
1000	1.0	900	2100	1250	1850	2400	2050	2250/2300	2050	2250/2300	4150	1400	50
	1.6	900	2100	1250	1850	2400	2050	2250/2300	2050	2250/2300	4200	1400	80
	1.75	900	2100	1250	1850	2400	2050	2250/2300	2050	2250/2300	4250	1450	90/105/120
	2.0	900	2100	1250	1850	2400	2050	2250/2300	2050	2250/2300	4350	1600	80/105/120
	2.5	900	2100	1250	1850	2400	2100	2250/2300	2100	2250/2300	5000	1950	105/120
1050	1.0	900	2100	1250	1950	2400	2050	2350/2400	2050	2350/2400	4150	1400	50
	1.6	900	2100	1250	1950	2400	2050	2350/2400	2050	2350/2400	4200	1400	80
	1.75	900	2100	1250	1950	2400	2050	2350/2400	2050	2350/2400	4250	1450	90/105/120
	2.0	900	2100	1250	1950	2400	2050	2350/2400	2050	2350/2400	4350	1600	80/105/120
	2.5	900	2100	1250	1950	2400	2100	2350/2400	2100	2350/2400	5000	1950	105/120
1150	1.0	1000/1100	2100	1200	2100	2400	2200/2100	2500/2550	2200/2100	2500/2550	4250	1700	50
	1.6	1000/1100	2100	1200	2100	2400	2200/2100	2500/2550	2200/2100	2500/2550	4350	1700	80
	1.75	1000/1100	2100	1200	2100	2400	2200/2100	2500/2550	2200/2100	2500/2550	4500	1750	90/105/120
	2.0	1000/1100	2100	1200	2100	2400	2200/2100	2500/2550	2200/2100	2500/2550	4700	1800	80/105/120
	2.5	1000/1100	2100	1200	2100	2400	2250/2150	2500/2550	2250/2150	2500/2550	5100	1950	120
1250	1.0	1000/1100	2100	1300	2100	2400	2300/2200	2500/2550	2300/2200	2500/2550	4250	1700	50
	1.6	1000/1100	2100	1300	2100	2400	2300/2200	2500/2550	2300/2200	2500/2550	4350	1700	80
	1.75	1000/1100	2100	1300	2100	2400	2300/2200	2500/2550	2300/2200	2500/2550	4500	1750	90/120
	2.0	1000/1100	2100	1300	2100	2400	2300/2200	2500/2550	2300/2200	2500/2550	4700	1800	80/120
	2.5	1000/1100	2100	1300	2100	2400	2350/2250	2500/2550	2350/2250	2500/2550	5100	1950	120
1350	1.0	1100/1200	2100	1400	2100	2400	2400/2300	2500/2550	2400/2300	2500/2550	4250	1700	50
	1.6	1100/1200	2100	1400	2100	2400	2400/2300	2500/2550	2400/2300	2500/2550	4350	1700	80
	1.75	1100/1200	2100	1400	2100	2400	2400/2300	2500/2550	2400/2300	2500/2550	4500	1750	90/120
	2.0	1100/1200	2100	1400	2100	2400	2400/2300	2500/2550	2400/2300	2500/2550	4700	1800	80/120
	2.5	1100/1200	2100	1400	2100	2400	2450/2350	2500/2550	2450/2350	2500/2550	5100	1950	120
1600	1.0	1100/1200	2100	1600	2100	2400	2550/2500	2500/2550	2550/2500	2500/2550	4250	1700	50
	1.6	1100/1200	2100	1600	2100	2400	2550/2500	2500/2550	2550/2500	2500/2550	4350	1700	80
	1.75	1100/1200	2100	1600	2100	2400	2550/2500	2500/2550	2550/2500	2500/2550	4500	1750	90/120
2.0	1100/1200	2100	1600	2100	2400	2550/2500	2500/2550	2550/2500	2500/2550	4700	1800	80/120	
备注	中分式/旁开式 Center opening /side opening			轿厢净高 (不含吊顶) Height of the elevator car			中分式/旁开式 Center opening /Side opening		中分式/旁开式 Center opening /Side opening				

对重侧置贯通门系列乘客电梯KLK1参数表（银燕系列）

Counterweight Side Opposite Door Type Passenger Elevator KLK1(Silver Swallow Series)

载重量 (Kg) Loading capacity	额定速度 (m/s) Rated speed	开门宽度 (mm) Door opening width	开门高度 (mm) Door opening height	轿厢尺寸(mm) Car size			井道尺寸(mm) Hoistway size		机房尺寸(mm) Machine room size		顶层高度 (mm) Top floor height	底坑深度 (mm) Pit depth	最大提升高度 (m) Max.travelling height
				宽 Width	深 Depth	高 Height	宽 Width	深 Depth	宽 Width	深 Depth			
630	1.0	800	2100	1100	1400	2400	1950/1900	1910/2052	1950/1900	1910/2052	4150	1400	50
	1.6	800	2100	1100	1400	2400	1950/1900	1910/2052	1950/1900	1910/2052	4200	1400	60
	1.75	800	2100	1100	1400	2400	1950/1900	1910/2052	1950/1900	1910/2052	4250	1450	90/95
800	1.0	800	2100	1100	1700	2400	1950/1900	2210/2352	1950/1900	2210/2352	4150	1400	50
	1.6	800	2100	1100	1700	2400	1950/1900	2210/2352	1950/1900	2210/2352	4200	1400	80
	1.75	800	2100	1100	1700	2400	1950/1900	2210/2352	1950/1900	2210/2352	4250	1450	90/105/120
	2.0	800	2100	1100	1700	2400	1950/1900	2210/2352	1950/1900	2210/2352	4350	1600	80/105/120
	2.5	800	2100	1100	1700	2400	2000/1950	2210/2350	2000/1950	2210/2350	5000	1950	105/120
1000	1.0	900	2100	1250	1850	2400	2050	2360/2502	2050	2360/2502	4150	1400	50
	1.6	900	2100	1250	1850	2400	2050	2360/2502	2050	2360/2502	4200	1400	80
	1.75	900	2100	1250	1850	2400	2050	2360/2502	2050	2360/2502	4250	1450	90/105/120
	2.0	900	2100	1250	1850	2400	2050	2360/2502	2050	2360/2502	4350	1600	80/105/120
	2.5	900	2100	1250	1850	2400	2100	2360/2500	2100	2360/2500	5000	1950	105/120
1050	1.0	900	2100	1250	1950	2400	2050	2460/2602	2050	2460/2602	4150	1400	50
	1.6	900	2100	1250	1950	2400	2050	2460/2602	2050	2460/2602	4200	1400	80
	1.75	900	2100	1250	1950	2400	2050	2460/2602	2050	2460/2602	4250	1450	90/105/120
	2.0	900	2100	1250	1950	2400	2050	2460/2602	2050	2460/2602	4350	1600	80/105/120
	2.5	900	2100	1250	1950	2400	2100	2460/2600	2100	2460/2600	5000	1950	105/120
1150	1.0	1000/1100	2100	1200	2100	2400	2200/2100	2610/2750	2200/2100	2610/2750	4250	1700	50
	1.6	1000/1100	2100	1200	2100	2400	2200/2100	2610/2750	2200/2100	2610/2750	4350	1700	80
	1.75	1000/1100	2100	1200	2100	2400	2200/2100	2610/2750	2200/2100	2610/2750	4500	1750	90/105/120
	2.0	1000/1100	2100	1200	2100	2400	2200/2100	2610/2750	2200/2100	2610/2750	4700	1800	80/105/120
	2.5	1000/1100	2100	1200	2100	2400	2250/2150	2610/2750	2250/2150	2610/2750	5100	1950	120
1250	1.0	1000/1100	2100	1200	2100	2400	2250/2150	2610/2750	2250/2150	2610/2750	5100	2200	150
	1.6	1000/1100	2100	1300	2100	2400	2300/2200	2610/2750	2300/2200	2610/2750	4250	1700	50
	1.6	1000/1100	2100	1300	2100	2400	2300/2200	2610/2750	2300/2200	2610/2750	4350	1700	80
	1.75	1000/1100	2100	1300	2100	2400	2300/2200	2610/2750	2300/2200	2610/2750	4500	1750	90/120
	2.0	1000/1100	2100	1300	2100	2400	2300/2200	2610/2750	2300/2200	2610/2750	4700	1800	80/120
1350	2.5	1000/1100	2100	1300	2100	2400	2350/2250	2610/2750	2350/2250	2610/2750	5100	1950	120
	1.0	1000/1100	2100	1300	2100	2400	2350/2250	2610/2750	2350/2250	2610/2750	5100	2200	150
	1.0	1100/1200	2100	1400	2100	2400	2400/2300	2610/2750	2400/2300	2610/2750	4250	1700	50
	1.6	1100/1200	2100	1400	2100	2400	2400/2300	2610/2750	2400/2300	2610/2750	4350	1700	80
	1.75	1100/1200	2100	1400	2100	2400	2400/2300	2610/2750	2400/2300	2610/2750	4500	1750	90/120
1600	2.0	1100/1200	2100	1400	2100	2400	2400/2300	2610/2750	2400/2300	2610/2750	4700	1800	80/120
	2.5	1100/1200	2100	1400	2100	2400	2450/2350	2610/2750	2450/2350	2610/2750	5100	1950	120
	1.0	1100/1200	2100	1600	2100	2400	2450/2350	2610/2750	2450/2350	2610/2750	5100	2200	150
	1.6	1100/1200	2100	1600	2100	2400	2550/2500	2610/2750	2550/2500	2610/2750	4250	1700	50
	1.6	1100/1200	2100	1600	2100	2400	2550/2500	2610/2750	2550/2500	2610/2750	4350	1700	80
备注	1.0	1100/1200	2100	1600	2100	2400	2550/2500	2610/2750	2550/2500	2610/2750	4500	1750	90/120
	2.0	1100/1200	2100	1600	2100	2400	2550/2500	2610/2750	2550/2500	2610/2750	4700	1800	80/120
备注	中分贯通 旁开贯通 Center opening opposite door /side opening opposite door			轿厢净高 (不含吊顶) Height of the elevator car			中分贯通 / 旁开贯通 Center opening opposite door /side opening opposite door		中分贯通 / 旁开贯通 Center opening opposite door /side opening opposite door				

用户应完成的工作

- 本图按有关电梯技术标准要求绘制，需复核后作为电梯安装依据。
- 机房内通向井道的所有孔洞四周应筑一高50mm以上，宽度适当的台阶。
- 曳引机承重梁如埋入墙内，则支承长度应超过墙中心20mm，且不应小于75mm。
- 安装完成后，地面装饰应与厅门地坎上表面有一高度适当的台阶，以防止水或其它杂物进入井道。
- 安装时浇灌的物体应能满足相关图示要求。

The user's tasks

- It makes the drawing according to the relevant lift technical standard, It needs to be checked and confirmed by the user before it becomes the lift installation proof.
- It shall have one above 50mm step with the proper width around the holes that lead to the well in side the machine room.
- It shall be embedded in the wall for the machine supporting beam of the traction machine, Then the supporting length shall be 20mm more than the wall center, It shall not be less than 75mm.
- After the installation completion, the ground decoration shall have a proper height step in the sill surface to prevent water or other impurity from entering into the well.
- The casting object in the installation shall satisfy the relevant drawing requirements.

全国分公司服务网络

National Branch Service Network

<p>辽宁分公司 销售热线: 024-31981333 传真: 024-31981222 地址: 沈阳市大东区滂江街26-1国际公寓2916</p>	<p>无锡分公司 销售热线: 0510-85861251 传真: 0510-85861252 地址: 无锡市滨湖区梁青路58号华邸国际大厦A座1501室</p>
<p>大连分公司 销售热线: 0411-86552277 传真: 0411-86552299 地址: 大连市中山区民康街15号报业大厦16层E</p>	<p>徐州分公司 销售热线: 0516-83919000 传真: 0516-83919005 地址: 徐州市庆丰路绿地城市广场瀛海写字楼A座706室</p>
<p>盘锦分公司 销售热线: 0427-2828611 传真: 0427-2829611 地址: 辽宁省盘锦市兴隆台区大商新玛特C座2102室</p>	<p>上海分公司 销售热线: 021-62828058/62827558 传真: 021-62828360 地址: 上海市延安西路1221号2203室</p>
<p>黑龙江分公司 销售热线: 0451-82346098 传真: 0451-82318292 地址: 黑龙江省哈尔滨市道里区群力第四大道399号汇智广场西楼1004室</p>	<p>浙江分公司 销售热线: 0571-89971040 传真: 0571-86590365 地址: 杭州市新塘路19号采荷嘉业5幢1204室</p>
<p>吉林分公司 销售热线: 0431-86770000 传真: 0431-81030300 地址: 长春市经济技术开发区临河街5445号圣豪汇商705室</p>	<p>安徽分公司 销售热线: 0551-62671797 传真: 0551-62313639 地址: 安徽省合肥市蜀山区望江西路69号西湖国际广场A座603室</p>
<p>北京分公司 销售热线: 010-65505559 传真: 010-65505562 地址: 北京市朝阳区八里庄西里97号住邦2000商务中心4号楼10层</p>	<p>芜湖分公司 销售热线: 0553-3856158 地址: 芜湖市镜湖区长江中路66号 徽商财富广场北楼1802室</p>
<p>内蒙古分公司 销售热线: 0471-6289116 传真: 0471-6922767 地址: 呼和浩特市回民区新华西街明泽广场A座21层2110室</p>	<p>江西分公司 销售热线: 0791-88223016 传真: 0791-88399056 地址: 南昌市高新开发区紫阳大道绿地新都会紫峰(幢)大厦写字楼34层3402室</p>
<p>河北分公司 销售热线: 0311-66792031 转 8002 传真: 0311-87893130 地址: 石家庄市建设南大街29号众鑫大厦818-820室</p>	<p>湖北分公司 销售热线: 027-82660063 传真: 027-85770699 地址: 武汉市江汉区淮海路中段泛海国际SOHO城2605-2606室</p>
<p>天津分公司 销售热线: 022-58306090 传真: 022-58306091 地址: 天津市红桥区光荣道与保康路交口宝能创业中心B座24层2412室</p>	<p>襄阳分公司 销售热线: 0710-3287220 传真: 0710-3287220 地址: 襄阳市高新区长虹北路万达小区1栋二单元1902室</p>
<p>山西分公司 销售热线: 0351-8371869 传真: 0351-8371859 地址: 太原市小店区平阳路1号金茂国际数码中心A座16层F室</p>	<p>湖南分公司 销售热线: 0731-85787755 传真: 0731-85787722 地址: 长沙市岳麓区岳麓大道57号奥克斯广场B座1127-1129</p>
<p>陕西分公司 销售热线: 029-88332244 传真: 029-88332244-831 地址: 西安市莲湖区唐延路北段22号金辉国际广场11层</p>	<p>重庆分公司 销售热线: 023-67877015 传真: 023-67877025 地址: 重庆市渝中区大坪正街160号万科锦程1栋26-6</p>
<p>甘肃分公司 销售热线: 0931-8811752 传真: 0931-8432645 地址: 甘肃省兰州市城关区澳兰名门B2座708室</p>	<p>四川分公司 销售热线: 028-61320037 传真: 028-87321179 地址: 四川省成都市高新区新世纪环球中心西区8-1-1707</p>
<p>新疆分公司 销售热线: 0991-4815313 传真: 0991-4815795-815 地址: 新疆乌鲁木齐沙依巴克区友好北路793号高地中心1105室</p>	<p>云南分公司 销售热线: 0871-68355199 传真: 0871-68355299 地址: 云南省昆明市五华区人民中路36号如意大厦11A室</p>
<p>河南分公司 销售热线: 0371-60189221 地址: 郑州市郑东新区康平路永平路郑东商业中心写字楼一号楼17楼1707</p>	<p>贵州分公司 销售热线: 0851-86515286 传真: 0851-86515286转81 地址: 贵阳市观山湖区金阳南路6号世纪城购物中心D栋写字楼23层5号</p>
<p>山东分公司 销售热线: 0531-55693961 传真: 0531-55693965 地址: 济南市市中区经四路13号万达广场C座办公楼2606室</p>	<p>广西分公司 销售热线: 0771-5517626 传真: 0771-5505713 地址: 南宁市民族大道92-1号新城国际1401号</p>
<p>青岛分公司 销售热线: 0532-68890088 传真: 0532-89092106 地址: 青岛市市北区山东路177号鲁邦广场B座1106-1107</p>	<p>广东分公司 销售热线: 020-38021060 传真: 020-38021410 地址: 广州市天河区天河路625号天娱广场东塔1007-1008室</p>
<p>烟台分公司 销售热线: 0535-6887005 传真: 0535-6887005 地址: 山东省烟台市莱山区银海路566号南山世纪华府13-2-2802</p>	<p>深圳分公司 销售热线: 0755-83865618 传真: 0755-83865618 地址: 深圳市福田区益田路3008号皇都广场A座1906室</p>
<p>南京分公司 销售热线: 025-58812988 传真: 025-84519155-81 地址: 南京市洪武路359号福鑫大厦西2602室</p>	<p>珠海分公司 销售热线: 0756-2260550 传真: 0756-2260695 地址: 珠海市香洲区银桦路102号6栋优特科技大厦909室</p>
<p>苏州分公司 销售热线: 0512-65166725 传真: 0512-65166721 地址: 苏州工业园区苏虹中路225号星虹国际1幢2113室</p>	<p>福建分公司 销售热线: 0591-88596982 传真: 0591-88594630 地址: 福州市五一中路88号平安大厦21G</p>